



# HexPly® M42

180°C curing epoxy matrix

## Product Data

### Description

HexPly® M42 is a high performance, self extinguishing, self adhesive, tough epoxy matrix for use in primary aerospace sandwich structures. It exhibits very high impact resistance and damage tolerance for a wide range of applications.

HexPly® M42 is a toughened epoxy resin system supplied with woven glass, carbon and hybrid glass/carbon fibres. HexPly® M42 was developed as a controlled flow system to operate in environments up to 120-130°C.

### Benefits and Features

- Hot melt chemistry (nominal 180°C cure)
- Self extinguishing
- Self adhesive on honeycomb (autoclave or vacuum bag)
- Very high temperature wet performances (120°C wet continuous service temperature)
- Low moisture absorption (0.74% after 1 week at 70°C 95% relative humidity (RH) and 3 weeks at 70°C 85% RH, measured on carbon/glass fibre laminate)
- Flexible cure cycle (from 135°C to 210°C with or without post-cure)
- High damage resistance

### Resin Matrix Properties

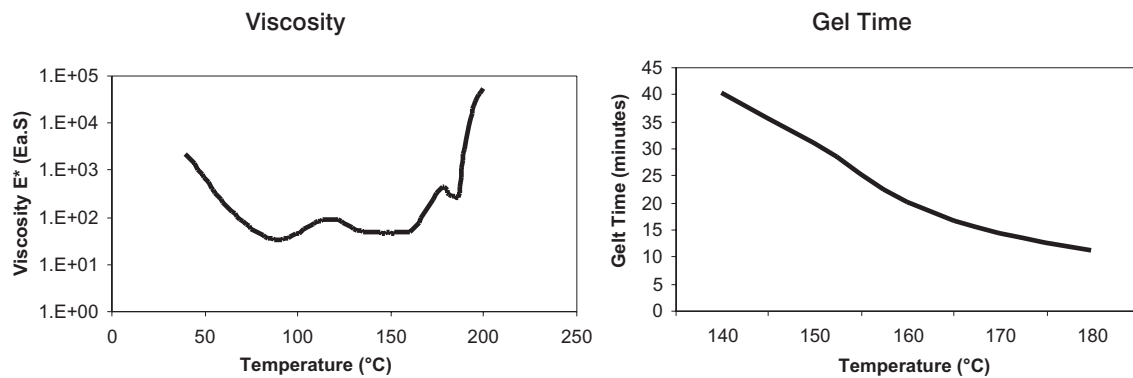

### Typical Neat Resin Data

Colour	Brown
Density	1.26 g/cm <sup>3</sup>
Glass Transition Temperature Tg Dry	193 °C
Glass Transition Temperature Tg wet 14 days in water @70°C	153 °C
Tensile Strength	77 MPa
Tensile Modulus	4.0 GPa
Tensile Strain	1.59 %
Poisson Ratio	0.40%
Linear coefficient of thermal expansion	59.10 <sup>-6</sup> °K <sup>-1</sup>
Fracture toughness, K <sub>1c</sub>	1.83 MPa.√m
Strain energy release rate, G <sub>1c</sub>	990 J/m <sup>2</sup>

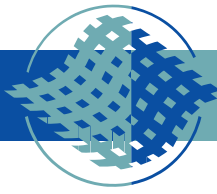

# HexPly® M42

## Prepreg Properties – HexPly® M42 Woven Carbon and Hybrid Prepregs

### Physical Properties

	Units	52%/G1177 Glass/Carbon	63%/120 E-Glass	50%/G939 HS Carbon	54%/G1088 Glass/Carbon
Fibre Density	g/cm <sup>3</sup>	2.1	2.6	1.78	2.25
Resin Density	g/cm <sup>3</sup>	1.26	1.26	1.26	1.26
Fibre areal weight	g/m <sup>2</sup>	185	107	220	135
Nominal Cured Ply Thickness	mm	0.21	0.15	0.22	0.11
Nominal Fibre Volume	%	42	35	55	53

### Mechanical Properties

Test	Standard	Units	Temp (°C)	Condition	52%/G1177 HS Carbon	63%/120 E-Glass	50%/G939 HS Carbon	54%/G1088 Glass/Carbon
90° Tensile Strength	EN2561	MPa	RT	Dry	400	280	850	377
			23	Wet	370	-	-	-
			130	Wet	320	-	-	-
			135	Wet	-	-	750	-
90° Tensile Modulus		GPa	RT	Dry	38	17	62.8	28
			23	Wet	37	-	-	-
			130	Wet	37	-	-	-
			135	Wet	-	-	60.0	-
90° Compression Strength	EN2850 Type B	MPa	RT	Dry	650	-	730	-
			23	Wet	590	-	-	-
			130	Wet	390	-	-	-
			135	Wet	-	-	530	-
90° Compression Modulus		MPa	150	Wet	-	-	-	370
			RT	Dry	37	-	-	-
			23	Wet	38	-	-	-
0° ILSS	EN2563 Short beam shear	MPa	130	Wet	36	-	-	-
			RT	Dry	-	55	65	48
			120	Dry	-	-	49	-
90° ILSS			135	Wet	-	-	35	32
			150	Wet	-	-	-	27
			RT	Dry	68	49,7	-	-
In-plane Shear Strength	EN 6031	MPa	130	Wet	34	-	-	-
			100	Wet	48	-	-	-
			RT	Dry	79	-	-	108
In-plane Shear Modulus		GPa	150	Wet	-	-	-	58
			100	Wet	-	-	-	3.0
			RT	Dry	3.5	-	-	-
Climbing Drum Peel	EN 2243-3	MPa	130	Wet	2.4	-	-	2.0
			150	Wet	-	-	-	-
			RT	Dry Top	-	-	49	47
			RT	Dry Bottom	-	-	59	53

Wet : 1 week at 70°C 95% relative humidity (RH) and 3 weeks at 70°C 85% RH

These are values obtained for G1177 with 0.21mm/ply, for 120 with 0.115mm/ply, for G939 with 0.22mm and for G1088 with 0.11mm.

### Curing Conditions

Monolithic Parts (autoclave)

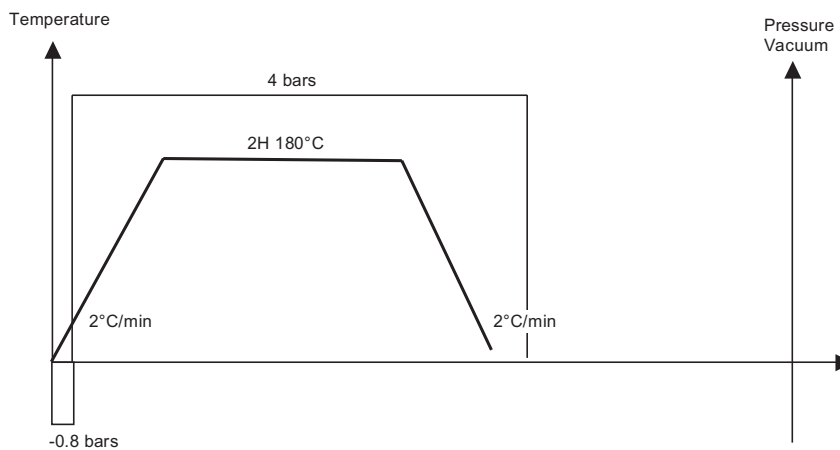

Sandwich parts (autoclave)

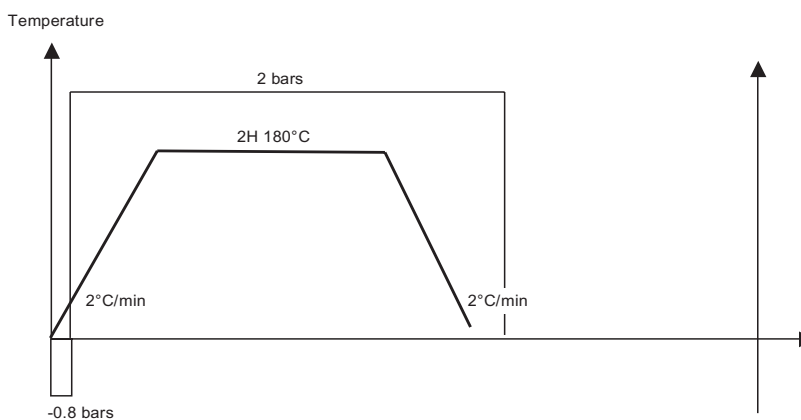

Vacuum bag cycle (monolithic and sandwich parts):

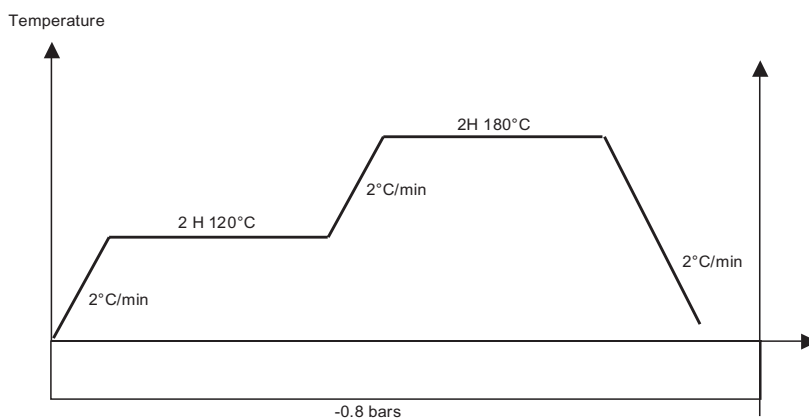



## **Prepreg Storage Life**

---

Out Life: 21 days at RT (23°C)  
Shelf Life: 12 months at -18°C (from date of manufacture)

### **Definitions:**

Out Life: The maximum accumulated time allowed at room temperature between removal from the freezer and cure.  
Shelf Life: The maximum storage life for HexPly® prepreg, when stored continuously, in a closed moisture-proof bag, at -18°C. To accurately establish the exact expiry date, consult the box label.

HexPly® M42 prepregs should be stored as received in a cool dry place or in a refrigerator. After removal from refrigerator storage, prepreg should be allowed to reach room temperature before opening the polyethylene bag, thus preventing condensation (A full reel in its packaging can take up to 48 hours).

### **Important**

All information is believed to be accurate but is given without acceptance of liability. Users should make their own assessment of the suitability of any product for the purposes required. All sales are made subject to our standard terms of sale which include limitations on liability and other important terms.

©Copyright Hexcel Corporation  
Publication FTA275b (Oct 2008)

### **For More Information**

Hexcel is a leading worldwide supplier of composite materials to aerospace and other demanding industries. Our comprehensive product range includes:

- Carbon Fibre
- RTM Materials
- Honeycomb Cores
- Carbon, glass, aramid and hybrid prepregs
- Reinforcement Fabrics
- HexTOOL® composite tooling material
- Structural Film Adhesives
- Honeycomb Sandwich Panels
- Engineered Core

For US quotes, orders and product information call toll-free 1-800-688-7734

For other worldwide sales office telephone numbers and a full address list please go to:

<http://www.hexcel.com/contact/salesoffices>