

**Redux[®]
Bonding
Technology**

REDUX BONDING TECHNOLOGY

Almost everything that is made by industry has component pieces which have to be joined together.

One of the most efficient methods of joining these components is adhesive bonding.

This technique is capable of replacing or supplementing traditional joining methods and has its own special advantages.

This manual explains the technology of bonding in a step-by-step guide.

We have been developing and using adhesives for over 60 years. The Redux® trademark has achieved worldwide acclaim for aerospace and industrial bonding.

Rev. July 2003
Publication No. RGU 034c

® Hexcel Registered Trademark
© Hexcel Corporation



REDUX BONDING TECHNOLOGY

Contents

	Page
Introduction	3
Designing for Bonding	4
Adhesive Selection	6
Surface Preparation	7
Adhesive Application	14
Assembly of the Components	15
Adhesive Curing	16
Quality Control	16
Safety	17
Appendices:	
1. Optimum Joint Design	18
2. Fault Finding Hints	20
3. Test Methods	21

INTRODUCTION

Why Bond?

Adhesive bonding is a reliable, proven and widely established technique for joining metals, plastics, composites and many other substrates.

Metal bonding techniques were widely adopted and developed during and after World War 2 by the aircraft industry, from where they have subsequently spread to other sectors. Today, designers and engineers can choose between adhesive bonding, bolting, riveting, welding or soldering. In many cases the more cost-effective method will be bonding.

Joints designed and bonded as recommended by Hexcel have several advantages over those made by traditional methods:

- Bonding eliminates the need for holes and avoids subjecting the joint to welding temperatures that weaken metals. The cured adhesive, unlike rivets or bolts, ensures even distribution of stresses which leads to improved fatigue performances.

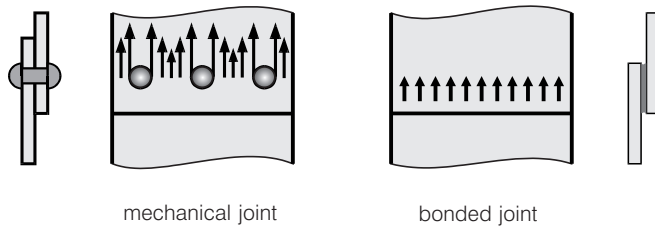

The riveted joint is highly stressed in the vicinity of the rivets (as shown by the arrows in the above diagram) and failure tends to initiate in these areas of peak stress. A similar distribution of stress occurs with spot welds and bolts. The bonded joint, however, is uniformly stressed. A continuous welded joint is likewise uniformly stressed but the metal in the heated zone will have undergone a change in performance.

- Bonding saves weight.
- On large area joints, bonded assemblies are generally less costly than their mechanical joint counterparts; simpler design, easier assembly and simpler tooling.
- Bonded joints can allow for the assembly of dissimilar materials.
- Bonded joints are electrically insulating and prevent electrolytic corrosion of conductor metals.

- Bonding joints enables the design of smooth external surfaces, and integrally sealed joints with minimum sensitivity to crack propagation.

- Bonded joints impart a stiffening effect compared with riveting or spot welding.

The diagram below shows how a joint may be designed to take advantage of the stiffening effect of bonding. Adhesives form a continuous bond between the joint surfaces. Rivets and spot welds pin the surfaces together only at localised points. Bonded structures are consequently much stiffer and loading may be increased (by up to 30-100%) before buckling occurs.

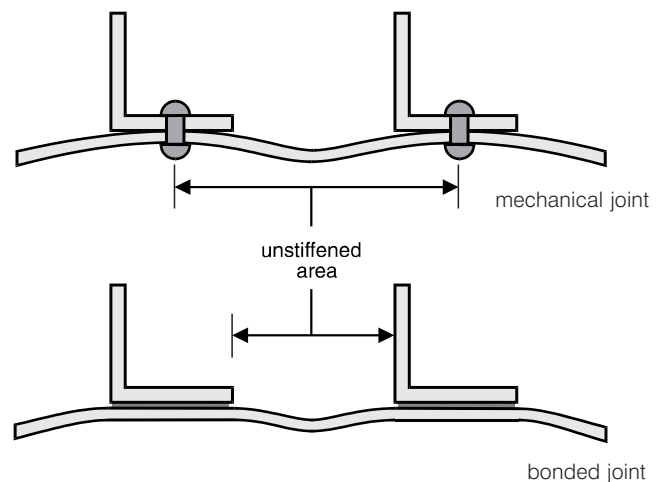

Adhesives in Film Form

Redux adhesives are ready-to-use in the form of flexible films and require only a short period of heat and pressure to form very strong bonds.

The film form ensures an optimum and controlled weight of adhesive containing exact proportions of resin and hardener. Film adhesives therefore require no mixing of components; and are clean, safe and easy to work with. In addition, they are supplied with protective release paper and/or polythene sheet on either side.

During the heating cycle the film liquefies and flows enough to wet the adherend surfaces, displaces any entrapped air (hence the need for pressure), and then cures to an infusible solid.

Film adhesives are particularly useful for bonding large areas and especially useful in the fabrication of sandwich panels, particularly those incorporating honeycomb core material.

REDUX BONDING TECHNOLOGY

DESIGNING FOR BONDING

Designing a bonded joint

Bonding with Redux film adhesives requires pretreatment of the substrates and a heating cycle. Consideration must therefore be given to whether the materials can withstand these processes.

Bonded joints may be subjected to a range of stresses including tensile, compressive, shear or peel and often a combination of these.

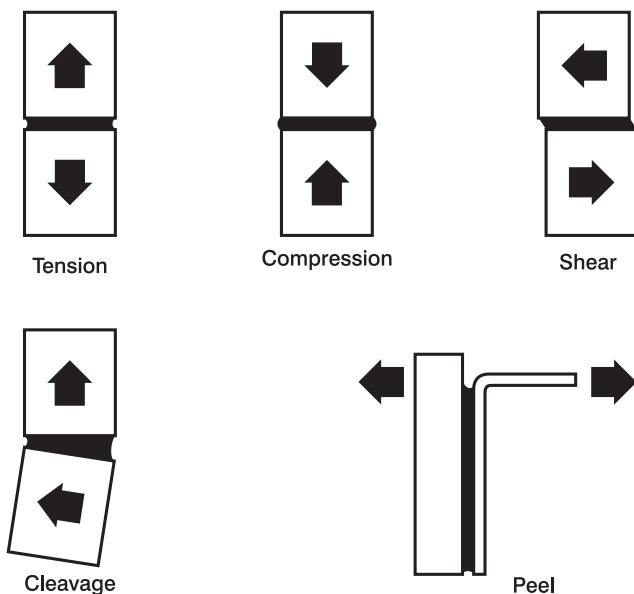

Adhesives perform best in shear, compression and tension. They behave relatively poorly under peel and cleavage loading. A bonded joint therefore needs to be designed so that the loading stresses will be directed along the lines of the adhesive's greatest strengths.

To indicate the performance of Redux adhesives, Hexcel supplies a range of data sheets which demonstrate how a particular adhesive performs under a range of standard tests such as shear and peel strengths. Details of joint testing are explained in Appendix 3.

For example, the standard test method for shear uses a simple lap joint made from metal sheet, usually an aluminium alloy, 1.63 mm thick with 12.5 mm overlap. The mean breaking stress* at room temperature ($23 \pm 2^\circ\text{C}$) will be in the range 15 to 50 MPa, depending on the adhesive. At the top end of this breaking stress range, joints made from aluminium alloy sheet of up to 1.5 mm thickness will yield or break in the metal.

*Mean breaking stress is the breaking load per unit width divided by length of overlap. MPa is the unit of stress in which mean breaking stresses, or shear strengths, are quoted. See Units (page 18).

Typical joint types

The basic types of bonded joints are shown diagrammatically. In practical structures two or more basic types may be used in combination - and the relative dimensions of the joints may vary from those shown in the diagrams. In most cases the stress distribution throughout the joint can be improved by leaving intact the small amount of resin squeeze-out (fillet) and tapering the overlap to remove the sharp, right-angle ends.

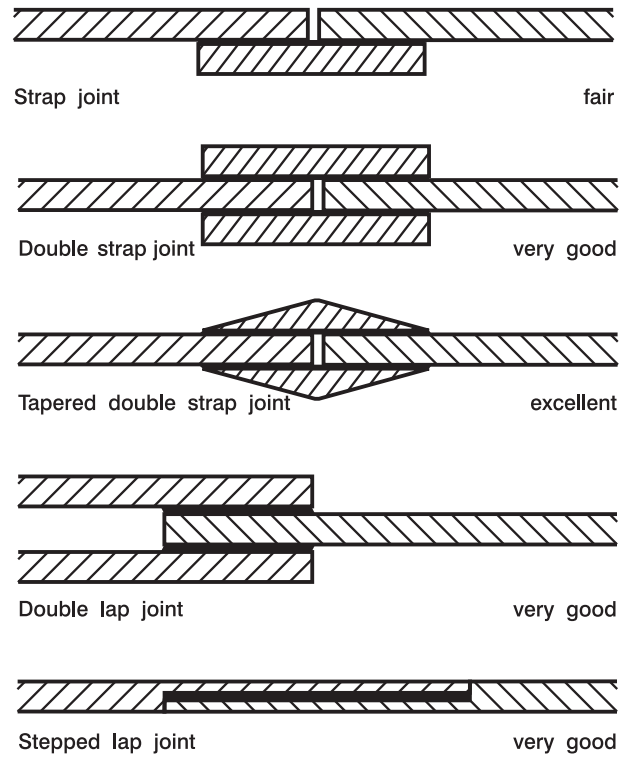
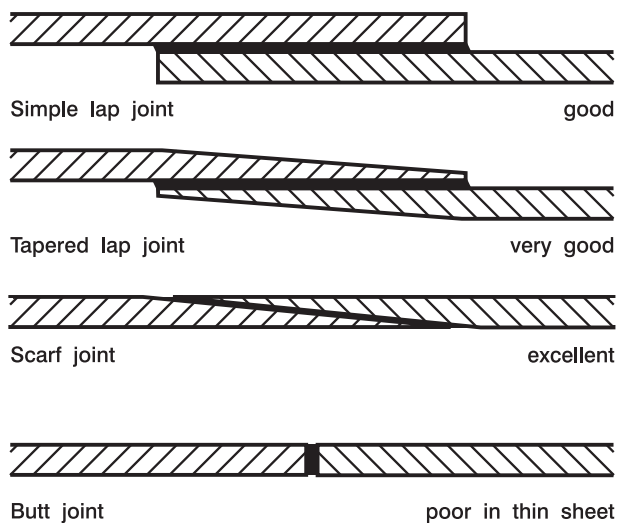

For optimum efficiency the amount of overlap can be calculated - See Appendix 1.

Large sheets of thin gauge material (metal or plastics) may be stabilised by bonded stiffeners made of the same material in similar gauge. Figure 1 shows a 'top hat' stiffener. Towards the edge of the sheet, the stiffener may be cut away (as shown) in order to reduce stress concentrations. The effect is similar to that of the scarf joint shown above.

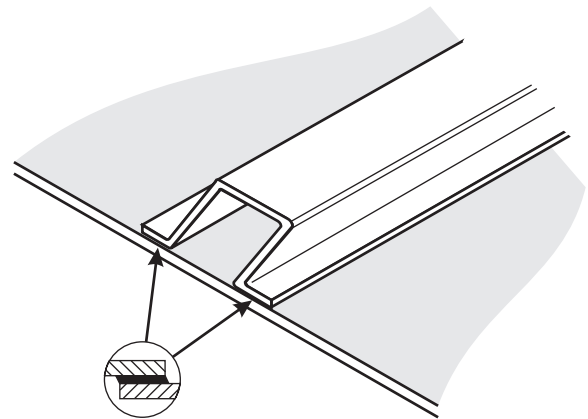

Fig. 1

Multi-layer structures may be built up by adhesive bonding and may also be bonded to other parts. In Figure 2 a multi-layer fibre-reinforced plastics laminate is joined to its neighbour by a multi-stepped lap joint. In Figure 3 an edge member is bonded into a sandwich panel. On loading, the stresses will be transferred into the panel. The honeycomb core is itself assembled and bonded to the facing sheets with adhesives.

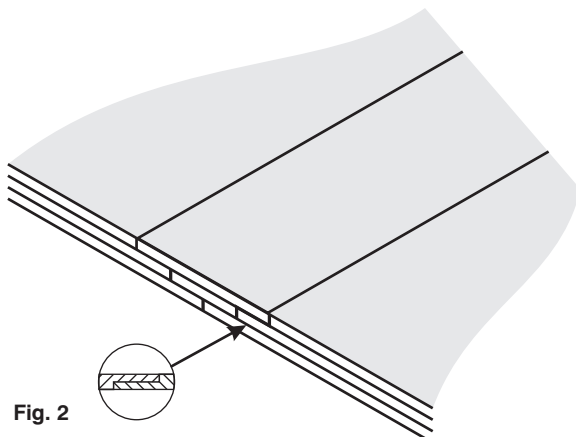

Fig. 2

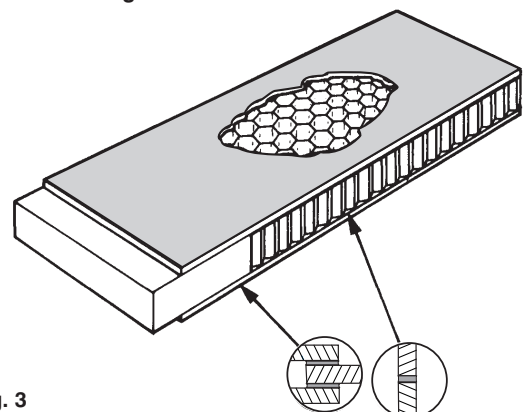

Fig. 3

REDUX BONDING TECHNOLOGY

ADHESIVE SELECTION

The comprehensive range of Redux film adhesives is suitable for a diversity of applications. The first stage of design for bonding is the selection of the most suitable adhesive. Hexcel publishes a selector guide with a summary of the main properties of the standard Redux adhesive range.

Generic type

Redux film adhesives are supplied in three main generic types:

1. vinyl-phenolic - giving the best hostile environment resistance properties with temperature resistance up to 70°C.
2. epoxy - giving higher strengths, toughness and temperature resistance up to 200°C.
3. bismaleimide - giving even higher temperature resistance to above 220°C.

Maximum service temperature

The temperature at which adequate strength is maintained varies according to adhesive type and can range from 70°C to 220°C. Most will retain their integrity down to -55°C.

The ultra-high temperature resistant adhesives usually have reduced toughness and peel strength.

Cure temperature

Film adhesives generally fall into ca. 120°C curing or ca. 180°C curing categories. Choice depends on equipment availability, energy economy, or service temperature requirements (usually the higher the operating temperature the higher the cure temperature).

Bondline thickness control

During heating under pressure the adhesive will tend to squeeze out from a joint. Some film adhesives contain either a lightweight fabric 'carrier' or microspheres which ensure an optimum minimum bondline thickness automatically. This is useful for bonding small areas to prevent excessive squeeze-out. Strength values often are slightly reduced by the presence of carriers and they prevent the use of the reticulation technique on to honeycomb core (see page 14).

Weight

For good overall properties and bonding to honeycomb core, areal weights of film adhesives in the range 150-400 g/m² should be used. Where weight is critical lightweight film (60-150 g/m²) can be adequate when close tolerance joints are achievable.

Type approval

Certain applications may require an adhesive to meet specification values for selected strength properties. Redux films are qualified to a wide range of international and specific aerospace specifications. Further details are available on request.

Compatibility

For co-curing with prepregs (fibre reinforced matrix composites) to form a bonded sandwich structure, or as a 'surface finishing' film for prepreg, both chemical and cure cycle compatibility are essential. Compatibility with surface pretreatment protection primers and honeycomb core jointing foams is also necessary.

SURFACE PREPARATION

Introduction

Whenever structural components are to be produced using adhesive bonding, the condition of the adherend surfaces must be considered. They are likely to be contaminated with materials which could affect adversely the performance of the resultant joint.

Surface pretreatment will, therefore, normally be necessary if optimum performance is to be achieved. It will be vital if good environmental or thermal durability is required.

Dependent on the substrate, surfaces are prepared by one of the following pretreatment procedures (for many substrates, this list is in increasing order of effectiveness):

- 1) Degrease only.
- 2) Degrease, abrade and remove loose particles.
- 3) Degrease and chemically pretreat.

Care must be taken to avoid contaminating the surfaces during or after pretreatment. Contamination may be caused by finger marking - or by cloths which are not perfectly clean - or by contaminated abrasives - or by sub-standard degreasing or chemical solutions.

Contamination may also be caused by other work processes taking place in the bonding area. Particularly to be excluded are oil vapours from machinery, spraying operations (paint, mould release agents, etc.) and procedures involving powdered materials.

Whatever the pretreatment procedure used, it is good practice to bond the substrates as soon as possible after completion, i.e. when the surfaces are most 'active' (surface properties are at their best) {1}.

Degreasing Methods

For nearly all bonding applications, the removal of all traces of oil and grease from the adherend is essential.

Remove all traces of oil and grease as follows:

(not recommended for some plastic adherends as they might well be attacked by the degreasing solvent. Refer to Hexcel for detailed advice.)

(a) Suspend the part in the vapour of a suitable alkaline degreasing agent{2} in a vapour degreasing unit. The unit may contain a compartment to enable initial washing in the liquid solvent.

For metallic substrates, and particularly aluminium, this vapour degreasing process can be augmented by immersion in a warm, aqueous solution of a suitable alkaline degreasing agent (for example, a 10-minute immersion of aluminium sheet in an aqueous solution of Turco T 5215® at 70°C) followed by a spray-rinse in clean water. If further chemical pretreatment is to take place then, the substrate will not, of necessity, have to be dried. If no further treatment is contemplated then the adherend should be dried thoroughly - preferably in a stream of warm air (ca. 40°C), e.g. in an air-circulating oven or from a domestic forced-air heater.

or Where a vapour degreasing unit is not available:

(b) Immerse successively in two tanks each containing the same solvent {2}. The first tank acts as a wash, the second as a rinse. (Currently, either 1,1,1-trichloroethane or trichlorotrifluoroethane are used, but in view of the pending legislation {2} the use of acetone, in spite of the associated flammability problems, should be considered). When the solvent in the wash tank becomes heavily contaminated, the tank should be emptied, cleaned out and refilled with fresh solvent {3}. This tank is then used for the rinse and the former rinse tank for the wash.

Environmentally more acceptable alternatives to these solvents are under development and include materials based on alcohols, terpenes and water. Hexcel will, themselves, be changing to any of these novel materials as soon as their efficacy has been proven, and strongly recommend that other users make a similar change at that time.

or

(c) If safety considerations permit, brush or wipe the adherend surfaces with a clean brush or cloth soaked in clean acetone. For fine work, washing down with solvent applied by aerosol spray may be a more suitable alternative; this technique also ensures that the solvent used is clean. Allow to stand for about 5 minutes to permit complete evaporation from the joint surfaces. Good local extraction will have to be employed (at the same time ensuring compliance with the requirements of any local or national environmental regulations).

or

(d) Scrub the adherends in a solution of liquid detergent. Wash with clean hot water and allow to dry thoroughly - preferably in a stream of warm (ca. 40°C) air, e.g. in an air-circulating oven or from a domestic forced-air heater.

REDUX BONDING TECHNOLOGY

SURFACE PREPARATION (continued)

Test for a clean bonding surface

The water-break test is a simple method to determine whether the surface to be bonded is clean. It is best suited to metals. If a few drops of distilled water applied to the adherend wet and spread - or if, on drawing the substrate from out of an aqueous medium, the water film does not break up into droplets - then the surface may be assumed to be free of contamination. Uniform wetting of the surface by water indicates that it will probably be likewise wetted by the adhesive.

It must be borne in mind that certain plastics, even when clean, may not be wetted by water but will be wetted by the adhesive. Furthermore, satisfactory wetting gives no information as to the potential bond strength. At best, it is a necessary - but not sufficient - requirement for the achievement of high bond strengths.

Abrading Methods

For many substrates (but not all - see the section on aluminium, for instance), light abrasion of the surfaces to be bonded can allow the adhesive to key better than when a highly polished adherend is used. Highly active surfaces, such as those produced immediately following abrasion, tend to have a better affinity for the adhesive.

As well as producing an active surface, abrasion pretreatments are generally intended to remove surface deposits, such as oxide tarnish, rust or mill scale, on metallic substrates, particularly those which are ferrous-based, or to remove the surface layer of 'plastics' to ensure elimination of all traces of release agent etc. In this latter case, care must be taken to avoid compacting the release agent into the surface which is being pretreated, instead of removing it.

In all cases, the use of air- or water-borne grit-blasting is, generally, the best method of achieving these ends; provided every effort is made to use dry, clean compressed air and to prevent contaminated abrading media from coming into contact with the surface to be pretreated.

The choice of grit type (fused alumina, chill-cast iron shot or silicon carbide) will be dependant on the substrate to be abraded - e.g. alumina grit would not be used on mild steel components because of the possibility of galvanic corrosion; chill-cast iron shot would be used. Selection of grit size will also depend on several factors: again, the metal to be pretreated, the type of equipment being used, the pressure and angle of blast impact and the blasting time. Grits in the range of 125 to 315 μm {4} are suitable, but the optimum size for the work in hand can only be determined by trials. In general, for soft materials the optimum grit size will be towards the finer (i.e. 125 μm) end of the range.

Note: Water-borne grit-blasting of ferrous materials necessitates thorough drying of the adherends immediately after pretreatment; alternatively, a rust inhibitor must be added to the water.

When grit-blasting plastic materials pretreatment times should be kept to a minimum to avoid surface melting.

If grit-blasting equipment is not available or the substrate (either metallic or plastic) is too delicate to withstand such pretreatment, then clean the surfaces to be bonded with a suitable abrasive cloth (e.g. Scotchbrite®), a hand- or power-operated wire brush or water-proof abrasive paper (the average particle size abrasive bonded to the paper should, again, be in the range of 125 to 315 μm).

When using such techniques, operating under wet conditions (i.e. in the presence of water) can assist in the removal of contaminant and keeps dust generation to a minimum. If wet techniques are used, then the substrate should be thoroughly dried immediately after pretreatment.

Any abrasion pretreatment carried out must be followed by a further operation to ensure complete removal of loose and loosely-bound particles (from both the abrasion medium and substrate). For example:

- (a) Lightly brush with a clean soft brush, or - preferably
- (b) Blow clean with an uncontaminated, dry (filtered) compressed-air blast.

The substrate should finally be degreased.

Chemical Pretreatments

The surface pretreatments described above, i.e. degreasing alone or degreasing followed by abrasion and removal of the loose particles is sufficient to ensure, for several substrate types, that good, strong bonds will be formed with the adhesive being used. However, for many adherends, to obtain maximum strength, reproducibility and long-term durability, a chemical pretreatment will be required to modify the surface, or surface chemistry, in such a way as to make it suitable for structural adhesive bonding.

For metallic adherends most of these pretreatments either involve acid etching or an acid etch followed by an acidic anodizing process. [SEE NOTE ON PAGE 13 FOR DISPOSAL OF WASTE]

Surface modification of plastic materials is, nowadays, frequently carried out by exposing the surface to be bonded to a controlled flame, plasma or corona discharge.

Specific Pretreatments For Specific Adherends

The following pretreatments are relatively well established but on certain occasions a different procedure (not given here) may prove more effective. (The BSI revision of CP 3012 : 1972 is a useful source of information)

Metallic Substrates

Individual alloys within each metal group (and the particular surface structures caused by different heat treatments) may respond differently to a given pretreatment. The effectiveness of one pretreatment over another can be shown only by comparative trials - using both the type of metal and the adhesive specified for the work.

In virtually all cases where chemical pretreatment has been used, the water-break test can be used to confirm the effectiveness of the process.

Painted Metals

Any paint, which has relatively low adhesion to metal, should first be stripped off and the metal surface so exposed should then be subjected to a suitable pretreatment.

Aluminium and Aluminium Alloys

Aluminium Honeycomb

Unless there are obvious signs of contamination, aluminium honeycomb does not require pretreatment prior to bonding.

Should, however, any oil or grease contamination be evident, then the affected slice should be immersed in the vapour of a suitable hydrocarbon solvent {2} in a vapour degreasing unit. After immersion, always allow sufficient time for the honeycomb core to drain dry. This is particularly important as liquid solvent held in the corners of the honeycomb cell can be very difficult to detect and must be removed before bonding.

Aluminium Sheet

Due to the relatively high ductility of aluminium, it is not recommended that such adherends are pretreated by any of the abrasion methods. Far better is a vapour and/or alkaline degrease followed by an acid etch (pickling) {5} or by a suitable anodizing process {6}. A controlled film of active, aluminium oxide, highly suitable for structural bonding, is grown on the surface of the aluminium; its thickness being dependent on the chemical process and the alloy used. Bonding should then take place within 2 - 8 hours of pretreatment {1}.

Chromic/Sulphuric Acid Pickling [CSA]

A suitable pickling solution of sodium dichromate in sulphuric acid, can be made up as follows:

Water	1.500 litres
Concentrated Sulphuric Acid [Sg: 1.83]	0.750 litres
Sodium Dichromate [$\text{Na}_2\text{Cr}_2\text{O}_7 \cdot 2\text{H}_2\text{O}$]	0.375 kg
(or Chromium Trioxide [CrO_3])	0.250 kg)
Water	make up to 5.0 litres

Warning: Handle concentrated sulphuric acid with care using all the recommended personal protection equipment;

always add to water.

Chromium trioxide is a powerful oxidising agent and is highly toxic; **particular care is essential when handling this chemical.** It, or the chromate, should be dissolved in **diluted** sulphuric acid.

Regulate the pickling bath at 60 - 65°C and then immerse the substrate to be pretreated, for 30 minutes. At the end of this time remove and immerse in a tank of water at ambient temperature. Follow this with a spray-rinse with cold water. The pretreated components can then be air-dried, preferably in an air-circulating oven whose air temperature is no greater than 45°C.

Bonding should take place within 8 hours {1}.

Chromic Acid Anodizing [CAA]

A thicker, more "robust" oxide film can be grown if chromic acid anodising is used. Here, the pickled aluminium substrates (under certain circumstances it may be sufficient to use only an alkaline degrease before anodizing) are clamped to the anode of a standard anodizing bath and are immersed in a solution of chromic acid, at 40°C, of the following composition:

Chromium Trioxide [CrO_3]	0.500 kg
Water	10.0 litres

The anodizing voltage is raised, over a 10-minute period, to 40 V, held for 20 minutes, raised over a 5-minute period, to 50 V and held for 5 minutes. At the end of this cycle the components are removed and immersed in a tank of water at ambient temperature. This is followed by a spray-rinse with cold water. The anodized components can then be air-dried, preferably in an air-circulating oven whose air temperature is no greater than 45°C.

Bonding of the unsealed components should take place within 4 - 6 hours {1}.

REDUX BONDING TECHNOLOGY

SURFACE PREPARATION (continued)

Phosphoric Acid Anodizing [PAA]

To obtain a more open oxide film but thinner than that produced by chromic acid anodizing, aluminium adherends can be anodized in phosphoric acid; the anodic oxide contains 'bound' phosphate which will impart some degree of durability to the final adhesive joint.

Here, the pickled aluminium substrates (under certain circumstances it may be sufficient to use only an alkaline degrease prior to anodizing) are clamped to the anode of a standard anodizing bath and are immersed in a solution of phosphoric acid, at 25°C, of the following composition:

"Syrupy" Orthophosphoric Acid [Sg: 1.65]	1.0 litres
Water	16.6 litres

(Concentration of phosphoric acid is 75 g/l)

The anodizing voltage is raised to 10 - 15V (preferably 15V) and is held for 20 - 25 minutes. At the end of this time the adherends are removed and immersed in a bath of water at ambient temperature. This is followed by a spray-rinse with cold water. The anodized adherends can then be air-dried, preferably in an air-circulating oven where the air temperature is no greater than 45°C.

Bonding of the unsealed components should take place within 2 - 4 hours {1}.

Sulphuric acid anodizing techniques can be used to pretreat aluminium and its alloys but significantly lower adhesive strengths and durability will result when compared with CSA, CAA or PAA pretreatments. This situation can be relieved by dipping the anodised components in a solution of phosphoric acid to dissolve away some of the anodic oxide layer to reveal a more open structure more amenable to adhesive bonding.

Pre-Anodized Aluminium

Decorative (sealed), anodized aluminium or aluminium alloys are, as such, not suitable for adhesive bonding; these types of substrate require stripping prior to use. Stripping is sometimes accomplished by abrasive blasting but this sort of treatment is not really to be recommended. The anodic oxide film is best removed by immersion in the chromic/sulphuric acid solution given above.

Once the sealed oxide layer has been removed, one of the conventional pretreatments for aluminium can be used.

Copper and Nickel

Degrease as above and then either abrade or etch at 23± 2°C in the relevant solution of concentrated nitric acid:

Material	Copper and Copper Alloys	Nickel and Nickel Alloys
Etch Solution	Concentrated nitric acid [Sg: 1.42] and water in the ratio of 1 : 3 [by volume].	Undiluted concentrated nitric acid [Sg: 1.42]
Immersion Time	30 seconds	5 seconds

Warning: Concentrated nitric acid is highly corrosive and a powerful oxidising agent; **particular care is needed when handling.**

After treatment, spray-rinse with clean, cold water followed by clean, hot water. Dry in a stream of hot air.

Optimum bond strength can then be obtained if the pretreated surfaces are primed with a solution of Araldite® DZ 81; this primer, however, requires drying, followed by curing at 175°C for 1 hour.

Cupronickel Alloys

Trials are recommended to establish the optimum solution concentration and immersion time (as in Copper and Nickel above) for each particular alloy.

Steel - Mild

Degrease as above and then, wherever possible, abrade using a grit-blaster loaded with chill-cast iron shot.

A chemical etching pretreatment can be used instead but all evidence appears to indicate that this is not the optimum pretreatment. To carry out such a treatment, immerse the adherends for 10 minutes at 60°C, in a solution of the following composition:

Industrial Methylated Spirits	2.0 litres
Orthophosphoric Acid [Sg: ca. 1.7]	1.0 litre

At the end of this time, remove the components from the solution and then, under clean, cold, running water, brush off any black deposit with a clean, stiff-bristle, nylon brush.

Absorb residual water by wiping with a clean cloth soaked with clean industrial methylated spirits or iso-propanol. Heat, in an air-circulating oven, for 1 hour at 120°C.

Several proprietary phosphating systems are also available for the pretreatment of mild steel. Again, the evidence appears to indicate that grit-blasting is the optimum form of treatment for adhesive bonding.

Steel - Stainless

Note: It is strongly recommended that, before attempting to bond stainless steel components, Hexcel is consulted. This is to establish the trials which should take place to determine the optimum method and conditions needed to obtain the best bond strengths with the particular stainless steel being used. Such trials will also take into account end usage; particularly the durability requirements.

Stainless steel (i.e. corrosion-resisting steel having a chromium content $\geq 9\%$ m/m) is well known to be difficult to bond, **especially where long-term environmental resistance is concerned.**

The correct pretreatment, therefore, is vital and, amongst other considerations, will be dependant on the minimum specified tensile strength of the substrate as well as the projected end use of the bonded component.

Several pretreatments are recommended by the British Standards Institute 1992 revision of CP 3012: 1972. In essence, these methods cover solvent and/or alkaline degreasing followed by surface abrasion or by the use of a chemical etchant. Grit blasting, using chill-cast iron shot, glass or alumina, is the ideal abrasion technique and etchants based on sulphuric, hydrochloric or phosphoric acid are recommended; etching conditions are 5 - 30 minutes at room temperatures of up to 65°C.

In many cases, the chemically pretreated substrates will require desmutting after etching and washing. This can be accomplished by immersion in the standard CSA pickling solution (see above) for 5 - 20 minutes at 60 - 65°C. **Once such a bath has been used for desmutting stainless steel the chromic/sulphuric acid cannot be used again for the pretreatment of aluminium.**

Work by Hexcel has shown that adequate bond strengths can be obtained on **fresh** specimens following grit-blast, sulphuric/oxalic acid etching or hydrochloric acid/Formalin/hydrogen peroxide etching. The latter has been shown to give better bath stability.

Titanium and Titanium Alloys

Degrease as above and then either abrade, ideally by grit-blasting, or etch and then anodize in chromic acid as follows:

Pre-etch, at ambient temperatures, for 10 - 20 minutes in a solution of:

Concentrated Nitric Acid [Sg: 1.42]	4.5 litres
Hydrofluoric Acid [Sg: 1.17]	0.450 litres
Water	10.0 litres

Warning: Both acids are highly corrosive and toxic. **Particular care is essential when handling these chemicals;** use all the recommended personal protection equipment. **Do not use glass equipment with hydrofluoric acid;** polythene or polypropylene containers are suitable.

Remove from the bath and then, under clean, cold, running water, brush off any black deposit with a clean, stiff-bristle, nylon brush.

Clamp the etched substrates to the anode of a standard anodizing bath (anode : cathode ratio of ca. 3 : 1) and immerse, at 40°C, in chromic acid of the following composition:

Chromium Trioxide [CrO_3]	0.700 kg
Water	10.0 litres

Warning: Chromium trioxide is a powerful oxidising agent and is highly toxic; **particular care is essential when handling this chemical.**

Raise the voltage to 20 V over a 5-minute period and hold (dependent on alloy type) for 5 - 30 minutes; the titanium should have developed a distinctive **blue** colouration.

Remove from the anodizing bath, spray-rinse with cold water and air dry, preferably in an air-circulating oven whose air temperature does not exceed 45°C.

REDUX BONDING TECHNOLOGY

SURFACE PREPARATION (continued)

Plastic Substrates

Tests or technical advice (from Hexcel or the substrate supplier) may be needed as to the degreasing solvent to be used for thermosetting or, more particularly, thermoplastic polymeric substrates (certain plastics are attacked by certain halocarbon or ketonic solvents).

Thermosetting Plastics

Castings, mouldings, laminates, etc., manufactured from: Amino, diallyl phthalate, epoxy, phenolic, polyimide or unsaturated polyester plastics.

Degrease and abrade as above.

Thermosetting Fibre-Reinforced Laminates

With wet lay-up, RTM or RIM components or laminates prepared from prepregs, it may be possible to design the laminating process so that one peel ply of fabric is placed on the surface to be bonded; this peel ply becomes part of the laminate on curing.

Just prior to bonding, the peel ply is peeled off, removing with it some of the excess cured matrix material, which exposes a fresh, clean surface for bonding.

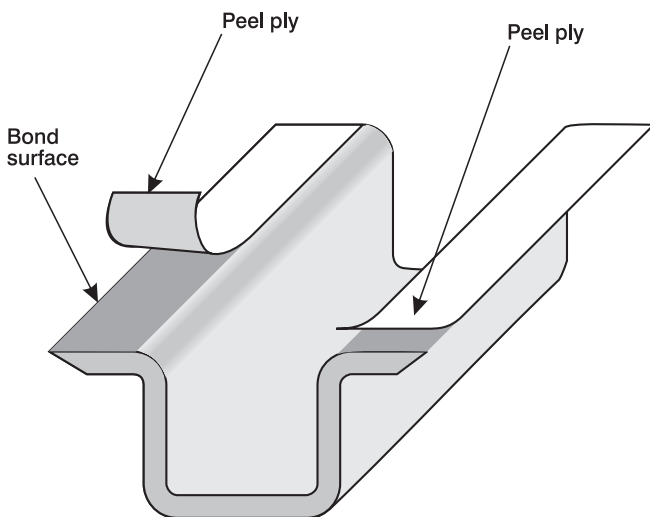

To obtain optimum bond strengths, the laminates should, if possible, be dried before bonding to remove any moisture absorbed from the atmosphere. This should be carried out, after removal of the peel ply (if present), in an air-circulating oven at a temperature at which no thermal damage will be imparted to the laminate {7}.

The peel ply technique gives a very reproducible surface on which to bond. However, a resin-rich layer remains on the laminate surface which can lead to a reduction in the actual level of bond strengths achievable.

This latter situation can be addressed by the careful use of hand-abrasion or grit-blasting pretreatments. Although this can lead to an improvement in bond strengths, the techniques are highly operator-dependent. This will invariably cause some fibre damage and occasionally (particularly when using hand-abrasion) an uneven removal of composite surface.

Thermoplastic Plastics

Thermoplastic polymeric substrates vary in the ease with which they can be bonded. Significant factors are the type and grade of polymer, the compounding ingredients and the moulding conditions. Tests may be needed to determine bond strength under a given set of conditions.

Many of the surface pretreatments for such plastics as:

ABS, acetals, polyamides (nylons), polycarbonates, polyesters, poly(meth)acrylates, polyolefines, polytetrafluoroethylene, polyethersulphones, polyurethanes, etc. have been, traditionally, chemical in nature. Currently, novel techniques such as flame, corona and plasma treatments are producing pretreated surfaces capable of supporting bonds with excellent strength properties.

For further details, refer to Hexcel.

Thermoplastic Fibre-Reinforced Laminates

Currently this type of substrate is, essentially, limited to those produced using polyetheretherketone or polyethersulphone matrices on carbon fibre.

Pretreatment should comprise some form of degreasing followed either by a controlled hand-abrasion or grit-blasting or by a corona discharge technique.

For further details, refer to Hexcel or check with the plastic supplier, who can generally recommend a treatment for bonding.

Plastic Foams

Foams made from phenolic resins, polyurethane, PVC, etc., usually require no pretreatment. It suffices to ensure that the surfaces are clean, dry and dust-free (a vacuum cleaner is recommended).

Non-Metallic Honeycombs

Honeycombs produced from such materials as aramid paper, require no pretreatment unless contaminated. However, higher bond strengths are obtained if the honeycomb is dried for 1 hour at 120°C just before bonding.

REFERENCES

{1} If the scheduling of bonding operations on multi-part assemblies causes delay between pretreatment and bonding, optimum surface properties may be preserved by priming the areas to be bonded with a suitable adhesive primer, or pretreatment protection solution immediately after pretreatment.

{2} The standard solvents are currently alkaline degreasing agents - such as Turco 4215 NCLT.

WARNING: Safety precautions must be observed where solvents are in use.

{3} The waste solvent should be disposed of in accordance with the manufacturer's instructions and the local regulations.

{4} FEPA Standard 42-GB-1984: Bonded Abrasive Grain Size Standard (Fused Aluminium Oxide and Silicon Carbide).

{5} The pickling procedure outlined in the text conforms to Method O of BSI Code of Practice CP 3012 (Method O of DEF Standard 03-2/1) as well as to the older specification DTD 915B. It is also approximately equivalent to the procedure developed by the Forest Products Laboratory, Wisconsin, USA, and which is known as the "FPL Etch".

{6} The two usual methods of anodising aluminium and its alloys for bonding are carried out in either chromic acid (essentially to DEF Standard 03-24/2) or phosphoric acid (essentially to the Boeing specification BAC 5555).

{7} Thermoset laminates should be dried in accordance with prEN 2823.

Note Also: For local suppliers of pretreatment materials and adhesive processing equipment, please refer to a suitable chemical and allied trades directory.

ENVIRONMENT

ALL WASTE, EXHAUSTED OR CONTAMINATED CHEMICALS **MUST** BE DISPOSED OF IN ACCORDANCE WITH THE MANUFACTURER'S INSTRUCTIONS AND NATIONAL AND LOCAL REGULATIONS. THIS IS NORMAL, EVERYDAY PRACTICE WITHIN THE CHEMICALS INDUSTRY - HEXCEL WILL BE HAPPY TO ADVISE.

REDUX BONDING TECHNOLOGY

ADHESIVE APPLICATION

All film adhesives have a 'shelf life' at room temperature, varying from a few weeks to several months, which can be extended by refrigeration.

If the adhesive has been cold stored allow the whole package to warm thoroughly to room temperature (ideally 24 hours) before opening. This will avoid condensation occurring and prevent problems with processing.

The film is supplied with a release paper backing on one surface and a polythene interleave on the other. Both must be removed before curing.

Two methods of adhesive application are common:

1. Cut the film to size before removing the release paper backing. Then lay the adhesive film on to the pretreated surface to be bonded and peel off the polythene interleave. Finally apply the other substrate to the exposed adhesive surface.
2. Unroll the film on to a cutting surface and remove the polythene interleave. Apply the pretreated surface of the component to be bonded. Cut around the profile then remove the release paper backing. Apply to the other surface to be bonded.

The films are essentially 'dry' but will tack readily to most prepared surfaces. The amount of tackiness is dependent on the film temperature and additional heat can be applied to increase tack if required.

Reticulation

When bonding honeycomb panels having perforated skins, blocking of the perforations can be minimised by first reticulating the film adhesive on to the ends of the honeycomb cell walls or the perforated skin.

On a large production scale this can be accomplished by first tacking the adhesive to the honeycomb or perforated skin and then passing over jets of hot air.

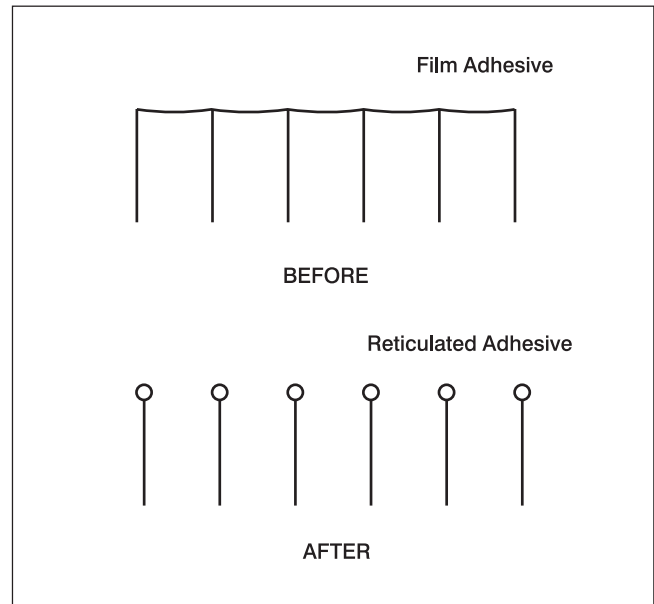

Surface finish

Additional resin at the surface of prepreg components can improve the finish by eliminating 'pin holes' especially in honeycomb cored components. Specially formulated film adhesives can be used for this purpose and are tacked into position against the tool or the prepreg and co-cured.

ASSEMBLY OF THE COMPONENTS

Assembly

As the component is heated to the cure temperature the adhesive will melt and flow. In order to produce a satisfactory bond the components must be held together without movement until after the adhesive has become solid and cooled. This is accomplished in a variety of ways depending on the type of adhesive, the type of component to be bonded and the production rate required.

■ Hydraulic press with heated platens.

Ideal for large flat components including sandwich panels. Good production rates are possible with multi daylight presses. Heating is usually by electricity, steam or heated oil and with suitable equipment, automatic cure cycles can be programmed.

Additional tooling will enable the flat press platens to be used for some curved or angled components.

■ Tooling fixtures

For complicated components with returns, purpose made tooling is required and curing accomplished in an oven or an induction heated station, pressure being applied by sprung clamps.

■ Vacuum bag

In the absence of a press, this is a way of applying holding pressure to flat or curved components while oven curing. Bags may be purpose made to suit using a rubber diaphragm. Some reduction in strength may occur due to the sub-atmospheric pressure increasing the volume of the unavoidable, entrapped air in the adhesive joint.

■ Autoclave

For very large or complicated, curved components requiring higher pressures, a large autoclave can be used and may cure several different components at the same time. The capital cost is high and the bonding time relatively slow.

■ Riveting and weld-bonding

For large, multi-component structures it is fairly common practice to 'fix' the assembly prior to bonding by the judicious placing of either rivets or spot-welds through the bondline to give dimensional stability to the unbonded structure (Figure 4).

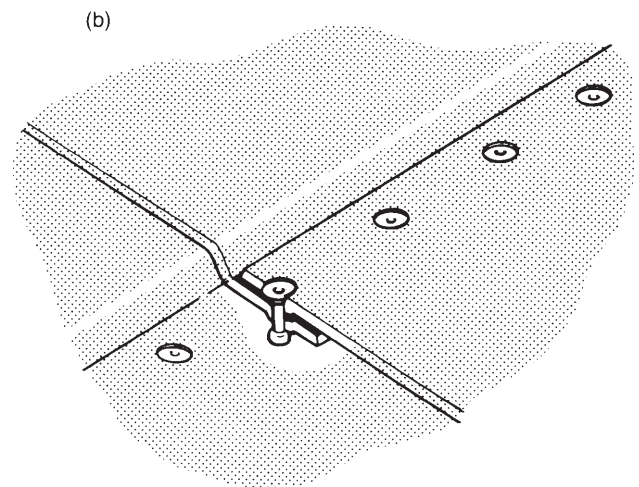
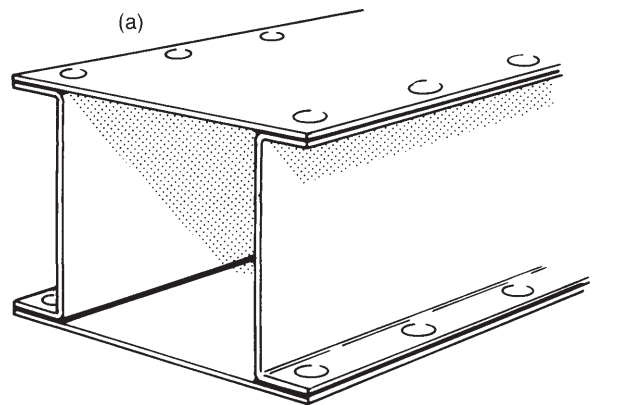

Fig. 4 Combination joints

(a) weld-bonding construction

(b) toggle lap-joint made with both rivets and adhesive.

REDUX BONDING TECHNOLOGY

ADHESIVE CURING

Adhesive curing

The time and temperature required for curing the film adhesive is specified in the individual Data Sheet for the adhesive chosen. A typical cure cycle is shown.

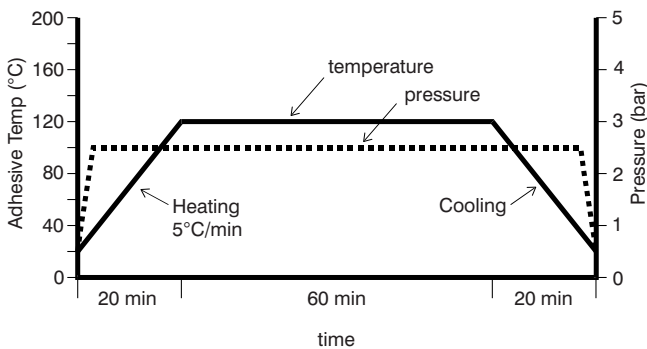

It should be noted that the temperature required is that of the adhesive and not that of the oven or press. To determine the adhesive temperature a thermocouple is required to be placed in an appropriate position within the component close to the adhesive.

The ramp rate (i.e. the rate at which the bondline temperature is allowed to rise to the required cure temperature) is usually controlled at 1-5°C/minute; an uneven heating rate between parts of the component can result in distortion due to 'bonded-in' thermal stresses.

The rate should then be lowered or the heating cycle 'dwelled' so that even heating occurs. The 'dwell' allows the temperature to stabilise across the component and will be applied **before** reaching the vital point at which gelation occurs.

After curing it is advisable to maintain pressure on the components until cooled, although if no stresses are present it may not be necessary.

Modified cure cycles are possible after suitable trials. For example, for high production rates of small components, it is possible to use induction heating at a higher cure temperature for a shorter time, as in the diagram below.

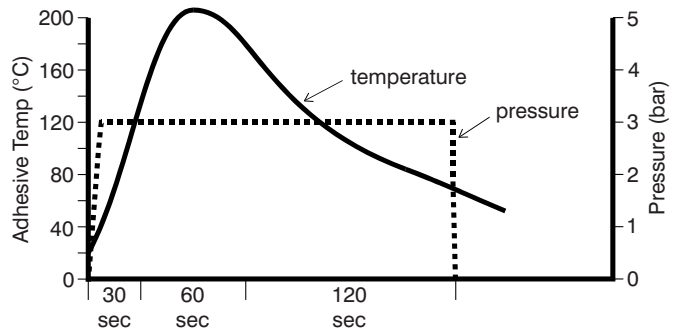

QUALITY CONTROL

Quality control can vary from simple strength tests on bonded joints to sophisticated non-destructive testing (NDT) techniques.

For many applications test specimens, pretreated and cured alongside the component, are sufficient. Standard test methods for lap shear strength, metal/metal peel strength and skin/core peel strength are used where appropriate and details are included in appendix 3.

SAFETY

Handling Precautions

Redux adhesives in film form are particularly free from handling hazards for the following reasons:

- film is covered on both sides by protective release paper and/or polythene which are not removed until final component assembly. It should be cut to shape before removing the protective coverings and virtually no handling of the film is necessary
- The film is dependent on elevated temperature for wetting-out the adherend surfaces
- volatile-free at normal room temperature
- splash-free, leak-free, spillage-free

However, the usual precautions when handling synthetic resins should be observed, and, in compliance with various national and international health and safety legislation, Hexcel has prepared Safety Data Sheets for each product. They are available on request.

Acids, caustic soda, etc.

Concentrated acids, oxidising agents (e.g. chromium trioxide, dichromates) and caustic soda are highly corrosive chemicals. Spillages and splashes can cause severe damage to eyes and skin, and attack ordinary clothing. Operators must wear a visor and protective clothing where these chemicals are in use.

The manufacturers' handling precautions must be observed.

Important Never pour water into acids. Always pour the acid in a slow steady stream into the water, with continuous stirring. Bear in mind that the handling hazard is intensified when the acid is hot.

REDUX BONDING TECHNOLOGY

APPENDIX 1 OPTIMUM JOINT DESIGN

Simple lap joints: Determination of dimensions

The shear strength of a simple lap joint (Fig. 1) depends on the nature of the metal, the adhesive, the thickness of the metal and the area of overlap.

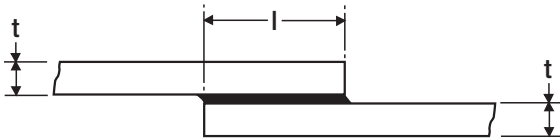

Fig. 1 Simple lap shear joint l = overlap; t = metal thickness

Given the loading required and the metal and adhesive to be used, it is possible to predict:

1. Optimum overlap on metals of given thickness.
2. Optimum metal thickness for a given overlap.

This overlap and thickness may be rapidly determined from a diagram based on results from one test programme.

The tests - to determine mean shear strengths of joints of various overlaps (l) and metal thickness (t) - must be sufficient to plot a curve of shear strength against t/l . Such a curve is shown in Fig. 2

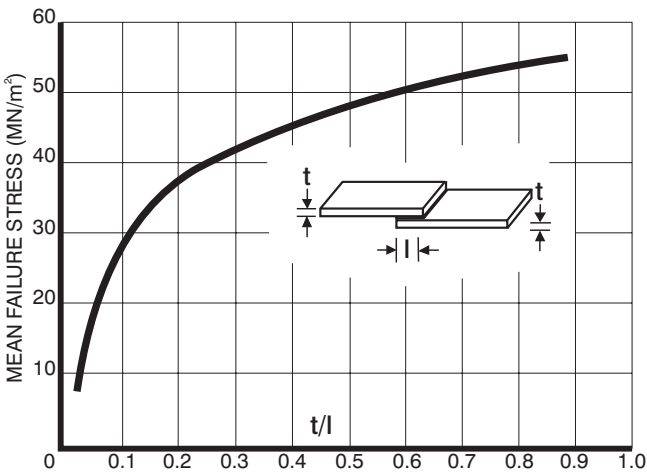

Fig. 2 Correlation diagram between shear strength and t/l of simple lap joints

The diagram relates the dimensions of the joint, the shear stress in the adhesive and the tensile stress in the metal.

Any particular point on an established t/l curve, such as the one given above, represents the state of stress in a particular joint and shows the relationship between the dimensions of the joint (x-axis), the mean stress in the adhesive (y-axis) and the mean tensile stress in the metal (the slope of a straight line drawn from the origin to the point in question).

Note: This relationship only holds true for experimental joints made with the same adhesive and metal and under the same bonding conditions as were used to establish the 'master' curve. In Figure 2, lap-shear joints were prepared using Araldite AT1 adhesive and BS 1470-H30 aluminium adherends.

Optimum overlap (l) is determined by using the diagram together with the formula:

$$\tau = \sigma \cdot \frac{t}{l}$$

This formula is derived from -

The known design requirements represented in Fig. 3.

P = load per unit width of joint

t = sheet thickness (t = thickness of thinner sheet in joints made of sheets of different thickness)

These establish:

$$\sigma = \text{mean tensile stress in the metal} = \frac{P}{t}$$

and by definition:

$$\tau = \text{mean shear stress in the joint} = \frac{P}{l}$$

Substituting for P gives: $\tau = \sigma \cdot \frac{t}{l}$

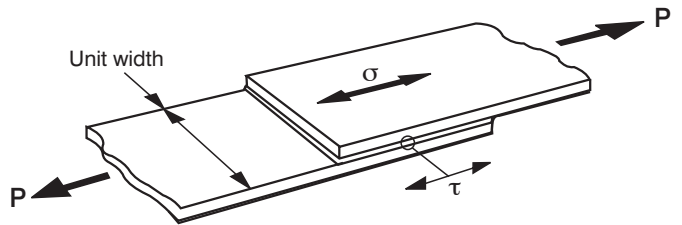

Fig. 3 Conventional signs for stresses in a lap joint

P = Load per unit width

σ = Mean tensile stress in metal

τ = Mean shear stress in joint

Optimum overlap (l) is determined as follows:

1. Calculate σ from P and t .
2. Starting from 0, mark on the diagram (e.g. Fig. 4) the straight line whose slope ($\tau / \frac{t}{l}$) is given by σ .
3. Where the straight line cuts the curve, read off the value for τ .
4. Having determined σ and τ , and knowing t , substitute these values in:

$$\tau = \sigma \cdot \frac{t}{l}$$

and calculate optimum overlap l .

Deviation from the optimum overlap reduces the efficiency of the joint. Too small an overlap causes the joint to fail below the required loading, whereas too large an overlap may mean an unnecessarily large joint.

Optimum sheet thickness (t) is determined as follows:

1. Calculate t from P and l .
2. Where this value of t cuts the curve, read off the value for $\frac{t}{l}$
3. Having determined $\frac{t}{l}$ and knowing l , calculate optimum thickness t .

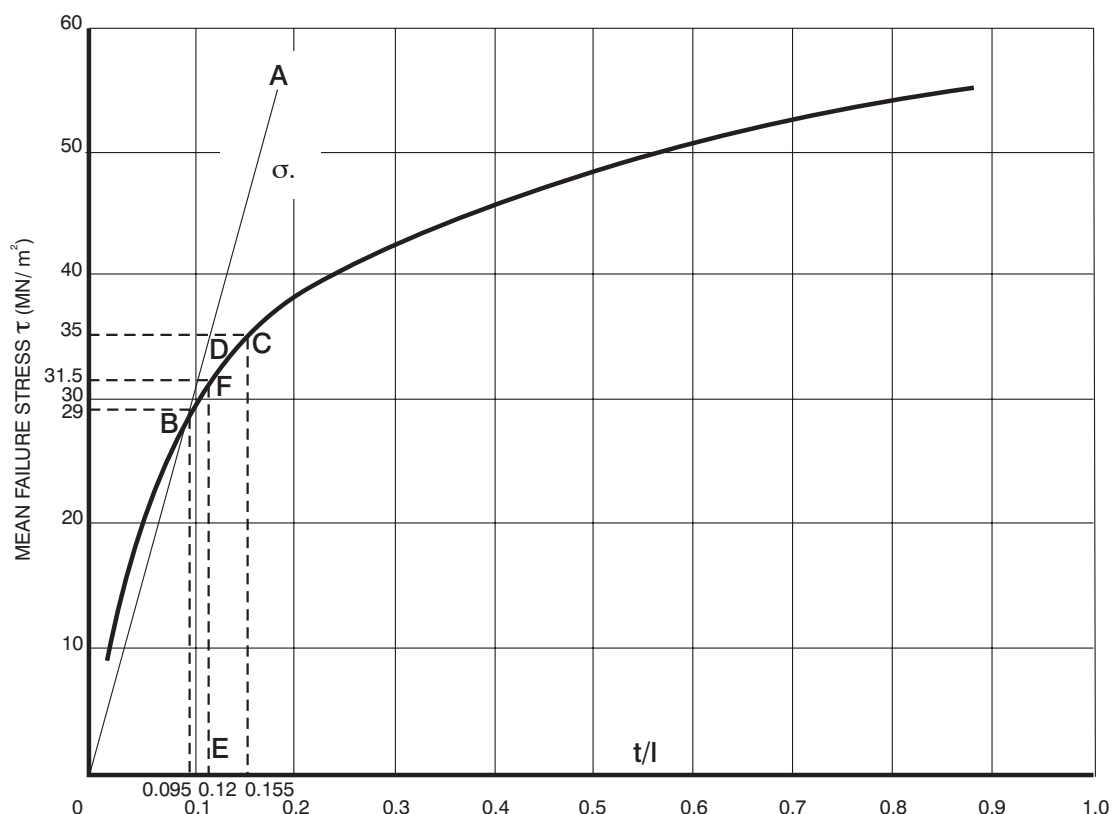

Fig. 4 Use of a correlation diagram in joint design. The curve shown relates to a typical simple lap joint.

Example using the correlation diagram to determine the optimum joint dimensions and mean failure stress

Example 1

Failure load required (P): 600 N per mm width of joint, i.e. 0.6 MN/m

Sheet thickness (t): 2 mm

Determine optimum overlap (l)

Tensile stress in metal ($\sigma = \frac{P}{t}$):

$$\frac{0.6 \text{ MN/m}}{2 \text{ mm}} = 300 \text{ MN/m}^2$$

$\sigma = 300 \text{ MN/m}^2 = \frac{t}{l}$ which gives straight line A0* on Fig. 4.

A0 cuts the curve at point B which determines

(i) the failure stress $\tau = 29 \text{ MN/m}^2$ and

(ii) $\frac{t}{l} = 0.095$

Since $t = 2 \text{ mm}$, $l = \frac{2 \text{ mm}}{0.095} = 21 \text{ mm}$

Optimum overlap is therefore 21 mm.

Example 2

Failure load required (P): 350 N per mm width of joint, i.e. 0.35 MN/m

Overlap (l): 10 mm

Determine optimum sheet thickness (t)

Failure stress in the adhesive (fixed by load required and overlap).

$$\frac{0.35 \text{ MN/m}}{10 \text{ mm}} = 35 \text{ MN/m}^2$$

Matching the mean shear stress in the joint (τ) to the shear strength of the adhesive (35 MN/m^2) gives point C on the curve in Fig. 4.

The point determines $\frac{t}{l} = 0.155$

Optimum sheet thickness is therefore $0.155 \times 10 \text{ mm} = 1.55 \text{ mm}$

Example 3

Overlap (l): 10 mm

Sheet thickness (t): 1.2 mm

Determine failure stress (τ)

$$\frac{t}{l} = \frac{1.2 \text{ mm}}{10 \text{ mm}} = 0.12 \text{ which is vertical line DE on Fig. 4.}$$

DE cuts the curve at point F which determines $\tau = 31.5 \text{ MN/m}^2$.

Mean failure stress is therefore 31.5 MN/m^2

*To construct A0 at a slope of 300 MN/m^2 , draw a line from 0 through the point on the diagram where

$$\tau = 30 \text{ MN/m}^2 \text{ and } \frac{t}{l} = 0.1.$$

REDUX BONDING TECHNOLOGY

APPENDIX 1 OPTIMUM JOINT DESIGN (continued)

Correlation diagrams modified to include safety margin

The curve in Figs. 2 and 4 represents mean failure stresses for joints immediately after bonding. In practice allowance should be made for reduction of bonding strength due to the effects of, for example, weathering, sustained loading or high temperatures during service. Test programmes corresponding to real service conditions are carried out on joints made with the actual metals. These programmes establish families of curves, each representing failure stresses at a particular percentage retention of initial strength. In addition, a safety factor is applied and each curve has to be lowered by an amount equal to t divided by the safety factor. The factored curve relevant to the required service life may then be used as described above.

Length of test-pieces used in test programmes to establish correlation diagrams

When carrying out shear tests to establish correlation curves,

the length of test-piece between the joint and the jaws of the testing machine should be maintained at the standard 50 mm with metal sheet 1.63 mm and thinner. With thicker gauge metal, the joint-to-jaw length should increase in proportion to thickness (double thickness - double length). Unless length is increased in thick joints, there may be marked scatter in the results, making the top end of the curve difficult to plot with accuracy.

Units

The units used in this publication belong to the rationalised metric system known as SI (Système International d'Unités). Within this system, the units Pa (pascal) and N/m² (newton/square metre) are alternatives. In Hexcel technical literature the shear strengths of Redux-bonded joints are normally stated in the unit MPa, but in Examples 1, 2 and 3 above, the unit N/m² is used, in order to make immediately apparent the relation between the equated values.

APPENDIX 2 FAULT FINDING HINTS

Fault	Cause	Remedy
Bond fails, leaving bare surface	Surface not properly pretreated	Check pretreatment procedures are correct
	Non removal of film's protective covers	Ensure parts are not contaminated after pretreatment
		Remove covers before assembly
Adhesive still soft after cure cycle	Adhesive not properly cured	Check recommended cure temperature of the adhesive is achieved throughout the curing cycle
Voids in bondline and thick bondline	Bonding pressure too low	Increase pressure
	No follow-up pressure	Check there is a constant application of pressure as adhesive flows
	Initial poor fit of parts	Check for distortion or mismatch before assembly with adhesive
Wedge-shaped or tapered bondline	Incorrect jiggling	Check for correct assembly of the component

APPENDIX 3 TEST METHODS

Lap Shear Test

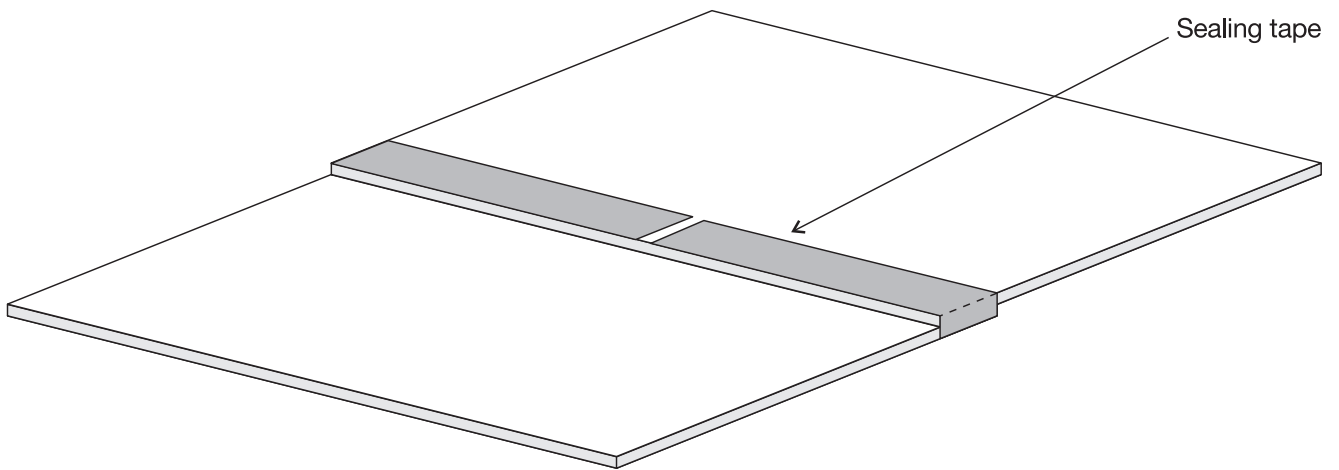

Fig. 1 Panel prior to bonding
(Cut into 25mm strips after bonding)

$$\text{Lap shear strength (N/mm}^2\text{)} = \frac{\text{Load (N)}}{312.5}$$

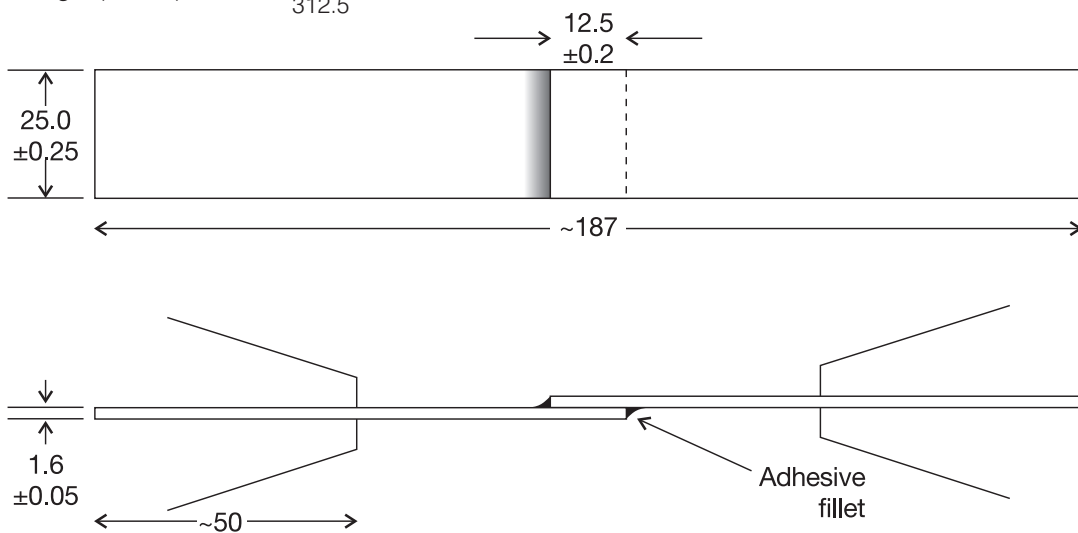

Fig. 2 Joint Dimensions
(All dimensions are in millimetres)

REDUX BONDING TECHNOLOGY

APPENDIX 3 TEST METHODS (continued)

Sandwich Peel Test

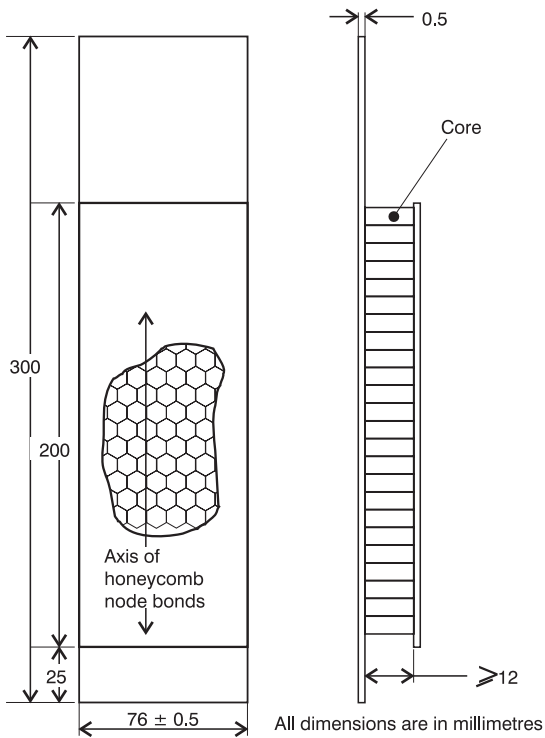

Fig. 1 Specimen Configuration

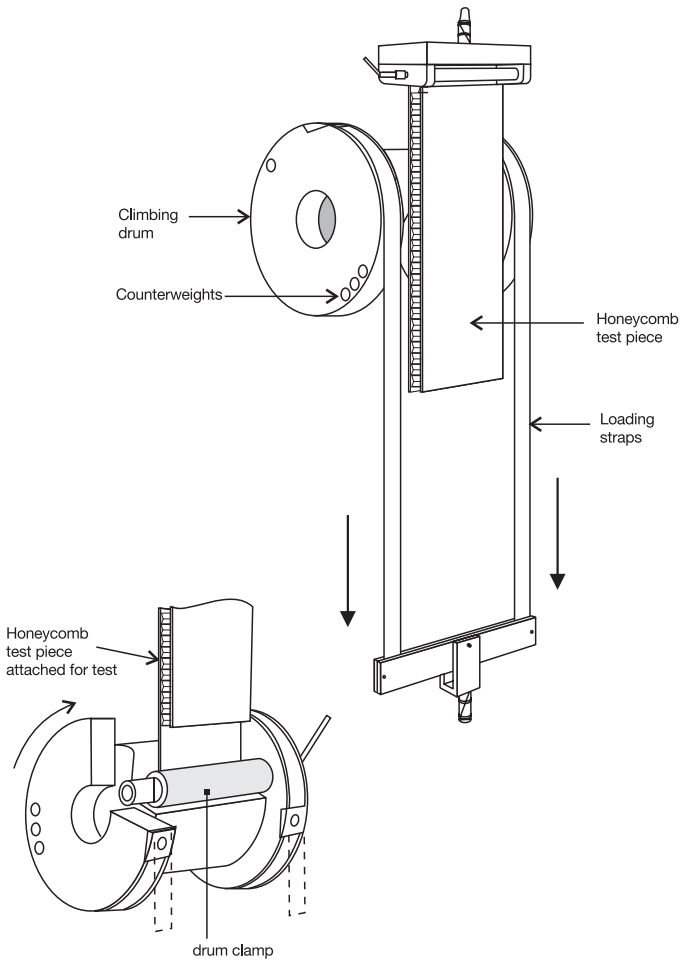

Fig. 2 Climbing drum apparatus

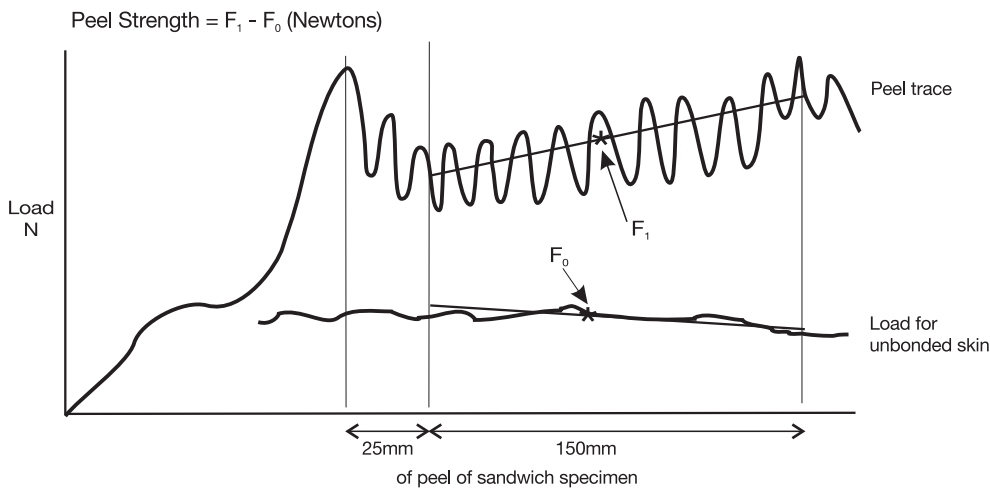

Fig. 3 Typical trace of climbing drum peel test

Metal/Metal Peel Test

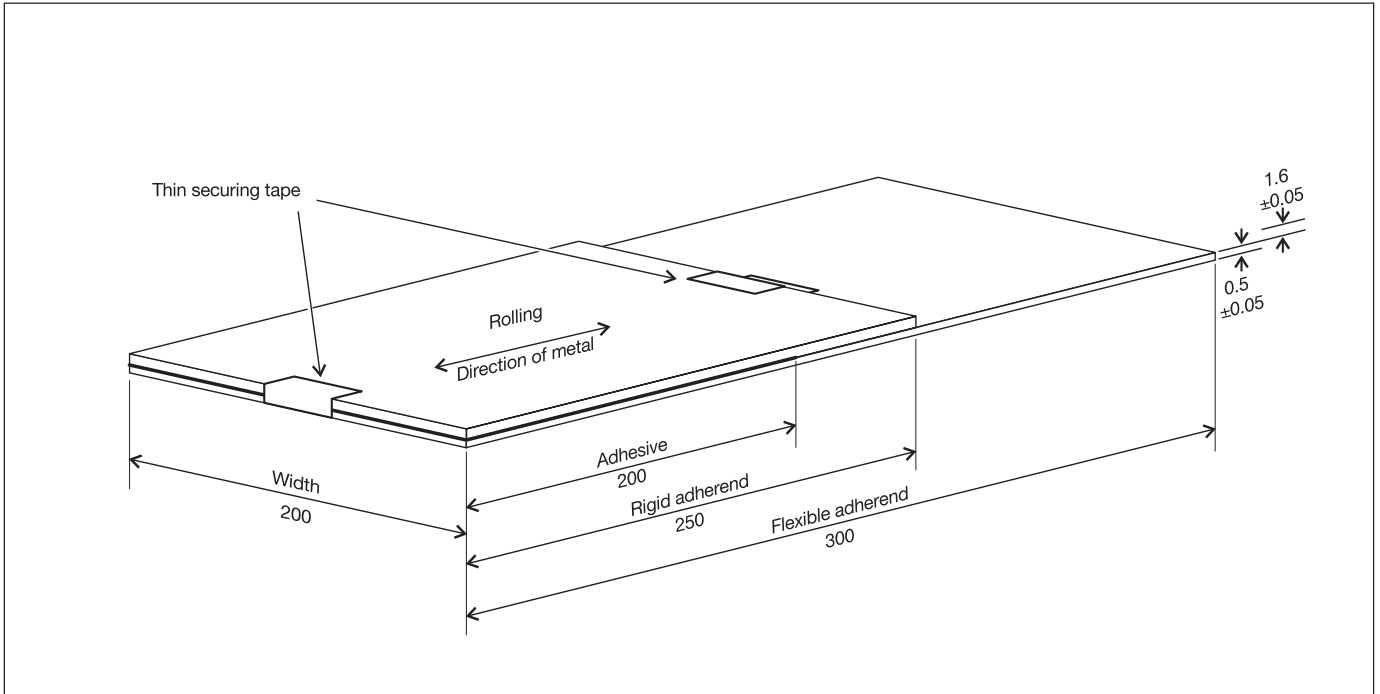

Fig. 1 Panel prior to bonding
(Cut into 25mm strips after bonding)

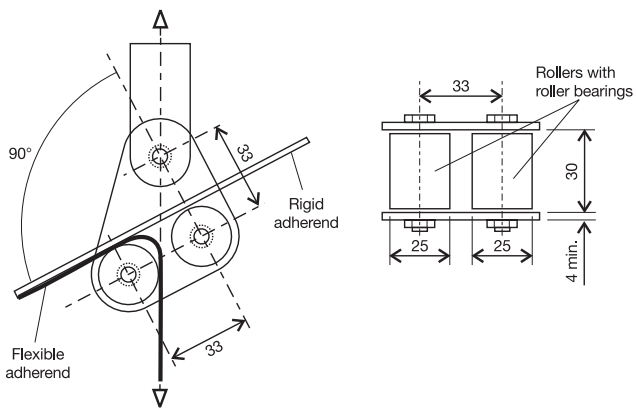

Fig. 2 Peel test apparatus
(All dimensions in mm)

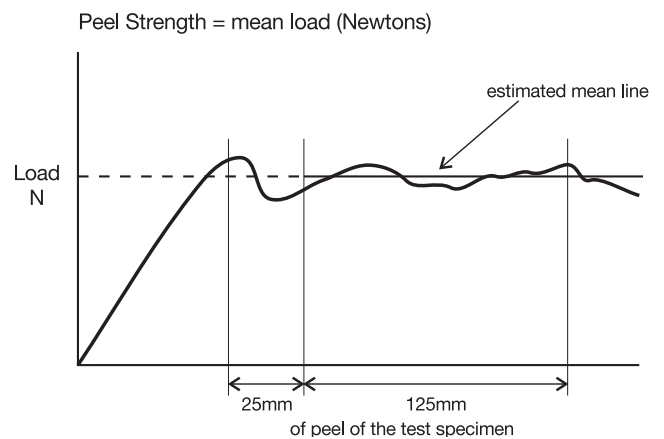

Fig. 3 Typical trace of metal/metal peel test

REDUX BONDING TECHNOLOGY

In addition to manufacturing Redux film adhesives, Hexcel has developed a whole range of structural composite materials:-

- Strafil[®], Vicotex[®] and Fibredux[®] prepregs
- Aluminium and Aramid honeycombs
- Hexlite[®] and Fibrelam[®] honeycomb sandwich panels
- Injectex[®] fabrics and resins for Resin Transfer Moulding
- Polyspeed[®] Laminates
- Modipur[®] Polyurethanes
- Fabrics, multiaxials and braids in Carbon, Glass, Aramid and hybrids

The information contained herein is believed to be the best available at the time of printing but is given without acceptance of liability, whether expressed or implied, for loss or damage attributable to reliance thereon. Users should make their own assessment of the technology's suitability for their own conditions of use and, before making any commitment with regard to the information given, should check that it has not been superseded.

Important

All information is believed to be accurate but is given without acceptance of liability. Users should make their own assessment of the suitability of any product for the purposes required. All sales are made subject to our standard terms of sale which include limitations on liability and other important terms.

For More Information

Hexcel is a leading worldwide supplier of composite materials to aerospace and other demanding industries. Our comprehensive product range includes:

- Carbon Fibre
- RTM Materials
- Honeycomb Cores
- Continuous Fibre Reinforced Thermoplastics
- Carbon, glass, aramid and hybrid prepregs
- Reinforcement Fabrics
- Structural Film Adhesives
- Honeycomb Sandwich Panels
- Special Process Honeycombs

For US quotes, orders and product information call toll-free 1-800-688-7734

For other worldwide sales office telephone numbers and a full address list please go to:

<http://www.hexcel.com/contact/salesoffices>