

COMPOSITE TRENDS

from **HEXCEL®**

Summary



49th INTERNATIONAL PARIS AIR SHOW
LE BOURGET
JUNE 20-26, 2011

49th SALON INTERNATIONAL DE L'AÉRONAUTIQUE ET DE L'ESPACE
PARIS LE BOURGET
20-26 JUIN 2011

A350 XWB progress

P.2



HexMC®

P.3



Acousti-Cap®

P.4



HexTOOL®

P.5



Hexcel.com

P.6



At the Paris Air Show 2011 Stand F80, Hall 2B; Chalet A136 Hexcel will be promoting a number of innovations in composites that have made Hexcel a leader in composite materials for Aerospace. Groundbreaking products include the HexPly® M21E/IMA carbon fiber prepreg that is being used to build all of the primary structures on the Airbus A350 XWB. Also the HexMC technology that has enabled over 100 carbon fiber/epoxy molded components to be manufactured for commercial aircraft.

A World of Composite Technologies



Composite Materials:

- HexTow® Carbon Fibers
- HexForce® Reinforcements
- HexPly® Prepregs
- HexFlow® Infusion Resins
- Redux® Adhesives

Engineered Products:

- HexWeb® EC Engineered Core
- Acousti-Cap®
- Fibrelam® Aircraft Flooring
- HexMC® Parts
- Composite Structures



49th INTERNATIONAL PARIS AIR SHOW
LE BOURGET
JUNE 20-26, 2011

49th SALON INTERNATIONAL DE L'AÉRONAUTIQUE ET DE L'ESPACE
PARIS LE BOURGET
20-26 JUIN 2011



Great progress on composite structures for the A350 XWB Built with HexPly® M21E/IMA carbon fiber/epoxy prepreg

Hexcel was awarded the contract by Airbus to supply HexPly® M21E prepreg, reinforced with HexTow® IMA carbon fiber, for all of the A350 XWB primary structures. Great progress has been made in recent months with various primary composite structures having been successfully manufactured by Airbus and its Risk Sharing Partners using HexPly® M21E including wing spars and wing covers, fuselage sections, keel beam and central wing box.

On the Hexcel stand at Le Bourget Hexcel will be displaying an A350 XWB fuselage test panel, manufactured by Composites Technology Center, Stade (Germany), using HexPly® M21E/IMA.



**A350 XWB airframe to contain
at least 53% carbon fiber composites.**



**Fuselage section 13-14
from Premium Aerotech**

**A350 XWB wing spar prototype
manufactured by GKN using
HexPly® prepreg**

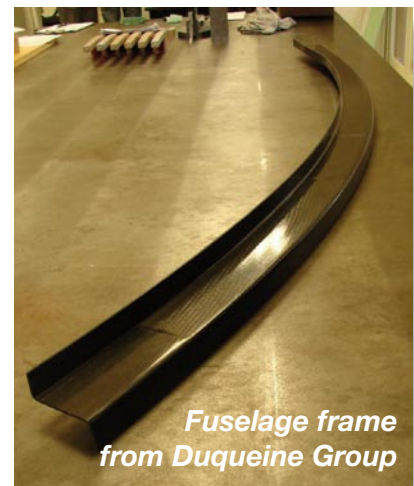

**Fuselage frame
from Duqueine Group**

**First composite lower
wing shells manufactured
at Illescas in Spain
©Airbus**

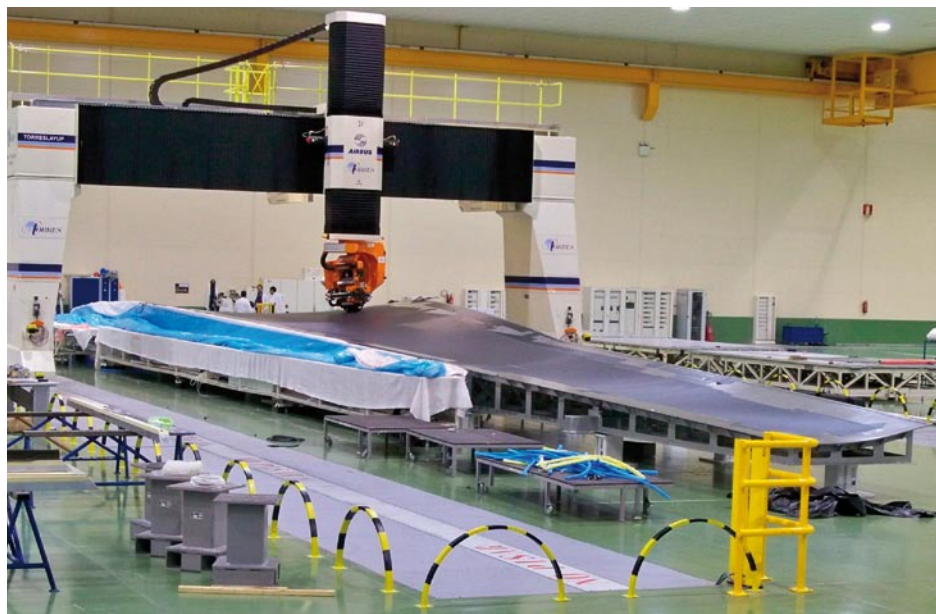

HexMC® Carbon Fiber/Epoxy Compression Molding Technology

HexMC® is Hexcel's patented carbon fiber/epoxy compression molding material and technology that enables structural complex-shaped parts to be molded cost-effectively, bringing weight-saving and performance advantages. Since HexMC® was launched, hundreds of HexMC® parts have been qualified for use on commercial aircraft including window frames, brackets, fittings, gussets, clips/cleats, intercostals, pans and static guide vanes., bringing weight-saving and performance advantages.

At Le Bourget Hexcel will showcase the Outlet Guide Vanes manufactured in HexMC® for the GE-Honda HF120 engine. OGV's are great candidates to benefit from HexMC® technology while providing weight savings that are comparable- or better – than those achieved with other aerospace carbon/epoxy solutions.

The HexMC® compression molding process allows 3D complex shapes to be produced

- Starting with a near shape preform
- Developed to preserve quasi-isotropic properties
- Net shape parts
- Robust process
- High throughput

The resulting aerospace components demonstrate:

- No galvanic corrosion
- Great damage tolerance
- Good fatigue properties
- Thereby opening the door to innovative designs and shapes.

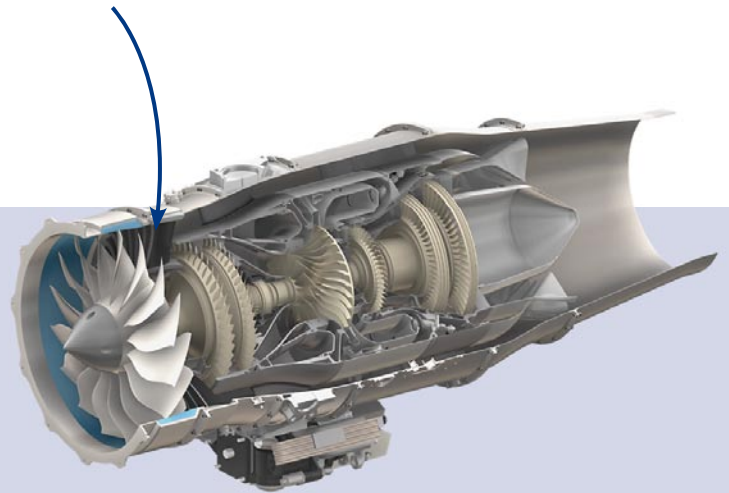

Optimized static guide vane demonstrator designed, analyzed, fabricated and tested by Hexcel

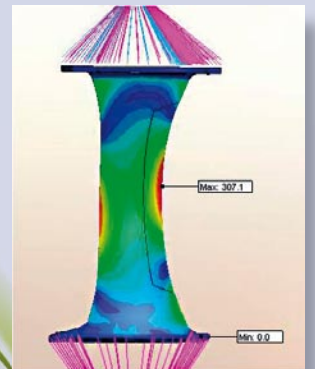

HexWeb® Acousti-Cap® Helping to reduce broadband sound in new generation aircraft engines

HexWeb® Acousti-Cap® is Hexcel's broadband sound reducing honeycomb that enables engine designers to achieve superior acoustical performance without a structural weight penalty. Acousti-Cap® consists of a permeable cap material embedded into a non-metallic honeycomb to create an acoustic septum. Customers specify the flow resistance characteristics, overall core thickness, number of caps in a cell and insertion depth. The result is a product tuned to their acoustic requirements. Quieter engines bring a number of advantages including recurring cost-savings from lower landing fees at airports, increased fleet flexibility and improved cabin comfort.



Photo: Guy Norris/AW&ST

Hexcel has added an aluminum version of Acousti-Cap® to the product range that provides comparable broadband noise reducing performance, with added cost-saving benefits. Aluminum Acousti-Cap® can withstand temperatures of up to 350°F/175°C during

fabrication of the nacelle core blanket and is processable using industry-standard techniques for forming, joining, cutting and machining. HexWeb® Acousti-Cap® is used by GE and Rolls-Royce to save weight and reduce engine noise by up to 30%.

The noise reduction achieved with HexWeb® Acousti-Cap® can lead to:

- Lower landing fees at airports - a recurring cost saving
- Increased fleet flexibility
- Improved carbon comfort
- Reduction in other acoustic treatments, resulting in lower weight and costs.

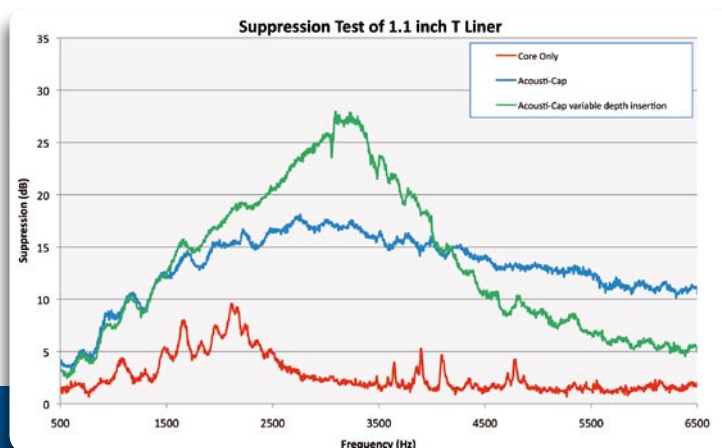

Suppression Liner test results demonstrating the superior sound suppression achieved with Acousti-Cap®. The use of variable depth insertion enables the performance requirements of the liner to be tuned to the noise reduction needs.

HexTOOL® - a unique tooling material

Enabling larger, high quality parts to be built from cost-effective composite tooling

Hexcel's HexTOOL® innovative machinable composite tooling material provides many benefits compared to conventional tooling prepregs and Invar. HexTOOL® can be machined without distortion, allowing complex shaped tools to be manufactured to tight tolerances that maintain vacuum integrity. With a coefficient of thermal expansion (CTE) that matches carbon/epoxy composites, HexTOOL® is lighter than metal tooling, allowing easier handling and reduced infrastructure investment. HexTOOL® provides fast heat-up and cool down rates relative to metal tools, leading to reduced production costs. It can be repaired and modified to accommodate design changes.

Tool manufactured for San Diego Composites by Touchstone Research Laboratory Ltd.

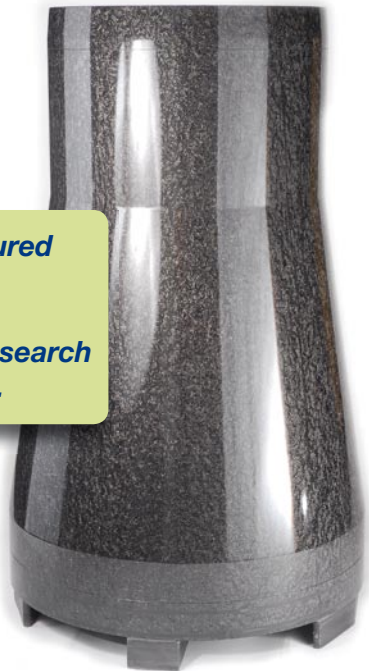

The BMI version, HexTOOL® M61, is capable of withstanding over 800 thermo-cycles at 180°C/350°F and provides superior resistance to micro-cracking during thermo-cycling. The epoxy version, HexTOOL® M81, is designed for 120°C/250°F curing parts and cures in 6 hours at 125°C/260°F, followed by a post cure of 2 hours at 205°C/400°F (shorter cure times are possible at higher temperatures).

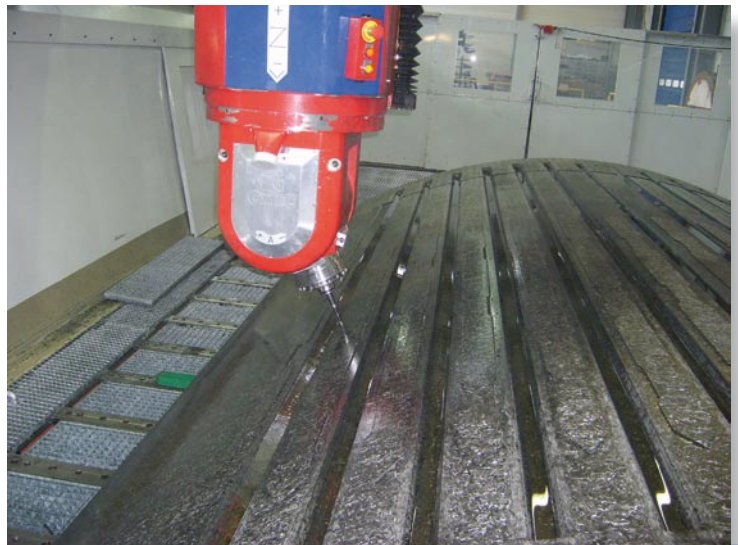

Features

- Lighter than metal tooling for easier handling and minimal investment in infrastructure
- Faster heat up and cool down rates
- Enables parts to be produced within tight tolerances
- Vacuum tight surface after machining
- Modifiable mold surface, adapting to design changes
- Repairable
- CTE of carbon/epoxy prepregs

Benefits

- Can be cut with steel rule die, razor blade, knife or electrical rotating cutter
- No warpage, even when large amounts of material are removed
- Vacuum integrity is maintained
- Rapid deposition as HexTOOL® is much thicker than standard composite tooling prepregs and does not require such accuracy during lay-up due to the quasi-isotropic nature of the material.

Hexcel launches new enhanced website



Learn more about
Hexcel's Innovative Composite Technologies for

- **AEROSPACE**
- **WIND ENERGY**
- **INDUSTRY**

by visiting

www.hexcel.com

&

STAND F80, HALL 2B; CHALET A136

A world of Composite technologies

Contact : communications@hexcel.com
www.hexcel.com

